

WD2 Series

The SHIELD™ WD2

Industrial LED Washdown Lighting



5935 West 84th St. | Indianapolis, IN 46278 | 1-800-840-5635 | www.SolasRay.com

Cat. #	Type
Notes	



Smooth curved upper surfaces shed water efficiently preventing accumulation.

CERTIFICATIONS / RATINGS



IP66 IP69K



KEY FEATURES AND BENEFITS

- Specifically designed for food processing environments and wash-downs.
- Seamless construction and smooth curved upper surfaces resist water accumulation.
- NSF rated for use in food processing environments.
- IP66 / IP69K protection ratings.
- Pressure wash ready - passed ISO 20653:2013.
- IK08 impact rating.
- Built in microwave motion sensor available.
- 4kV line-line, 4kV line-earth surge protection.
- 1-10 volt dimming.

INTENDED USE AND APPLICATIONS

- Poultry Processing
- Food Storage
- Hospitals
- Meat Processing
- Horticulture
- Warehouses
- Agriculture Processing
- Schools
- Stairwells & Tunnels
- Food Packaging
- Campuses
- Retail Stores

SPECIFICATIONS

Voltage	120-277 VAC / 277-480 VAC
Wattage	100W / 120W / 150W / 200W
Color Temp	5000 / 4000 / 3000 Kelvin
Housing	Corrosion resistant aluminum alloy
Color	White
Lens	Clear polycarbonate / optic lens
Lifetime	>100,000 hrs L70
Ambient Temperature	-30°C (-22°F) to 45°C (113°F)
CRI	Ra80

Beam Angles	60° / 90° / 120°
UGR	<28
Power Factor	>0.95
Protection	IP66 / IP69K
Warranty	5 Year Limited Warranty

LUMENS

100W	120W	150W	200W
14,000	16,800	21,000	28,000



PRODUCT ORDERING SELECTION

WD2							
Series	Watts	Kelvin	Voltage	Lens	Beam Angle	Mounting Options	Other Options
<input checked="" type="checkbox"/> WD2	<input type="checkbox"/> 100 - 100W <input type="checkbox"/> 120 - 120W <input type="checkbox"/> 150 - 150W <input type="checkbox"/> 200 - 200W	<input type="checkbox"/> 50 - 5000K (Std) <input type="checkbox"/> 40 - 4000K <input type="checkbox"/> 30 - 3000K	<input type="checkbox"/> U - 120-277 VAC <input type="checkbox"/> 48 - 277-480 VAC* <small>*200W model available in 120-277 VAC only.</small>	<input type="checkbox"/> PCC - Polycarbonate Clear (Standard) <input type="checkbox"/> OL - Optic Lens	<input type="checkbox"/> 120 - 120° Wide (Std) <input type="checkbox"/> 90 - 90° Medium <input type="checkbox"/> 60 - 60° Narrow	<input type="checkbox"/> EB - Eye Bolt (Std) <input type="checkbox"/> SC - Safety Cable (Std) <input type="checkbox"/> LH - Locking Hook <input type="checkbox"/> PA - Pipe Adapter	<input type="checkbox"/> MMS - Microwave Motion Sensor

WD2 Series

The SHIELD™ WD2

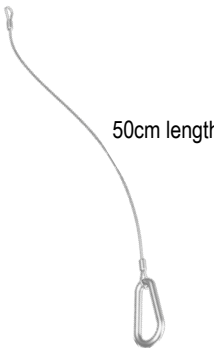
MOUNTING OPTIONS

#EB - Eye Bolt (Standard)	#SC - Safety Cable (Standard)	#LH - Locking Hook	#PA - Pipe Adapter
	 50cm length		 3/4" NPT

BEAM SPREAD

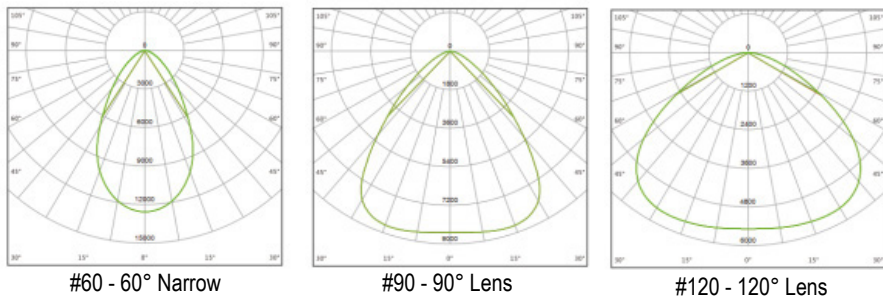

OTHER OPTIONS

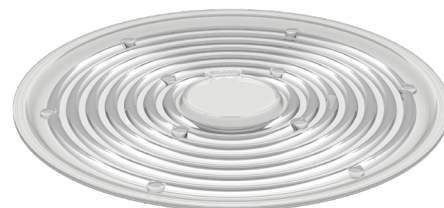

#OL - Optic Lens

WEIGHTS AND DIMENSIONS

WEIGHT

10.9 lb.

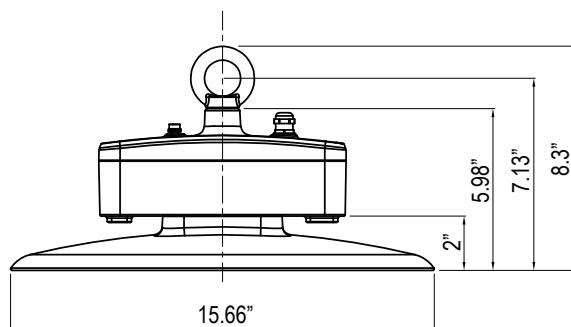

#MMS - Microwave Motion Sensor