

LQPO Series

The SABER™

Industrial LED Linear Task Light



5935 West 84th St. | Indianapolis, IN 46278 | 1-800-840-5635 | www.SolasRay.com

Cat. #	Type
Notes	

CERTIFICATIONS / RATINGS



IP66 IP69K



KEY FEATURES AND BENEFITS

The Saber™ is designed for the harsh environments found in food processing, heavy industrial manufacturing, warehouse, and distribution facilities. The IP66 waterproof design is an ideal task light to retrofit existing linear fluorescent as well as HID high-bay Fixtures

- IP66 / IP69K / NSF 2 rated.
- Power wash up to 1600 PSI.
- IK10 impact rating.
- Available in 4 foot and 8 foot lengths.
- 7,500 to 20,000 lumen packages available.
- Surface brackets and 120" adjustable cables included standard.
- Available wall mount brackets.
- Aluminum alloy construction with heat dissipating powder coat finish.
- 2.5 kV surge protection.
- 0-10V dimming.
- Buy American Act compliant.

NSF

NSF 2 - Food Splash Zone

An ETL sanitation mark on food service equipment that indicates equipment is tested to ANSI/NSF 2 and is fit for use in the production of food intended for human consumption, or the equipment is fit for use in an environment where food intended for human consumption is produced

FOOD AND BEVERAGE PROCESSING
 MANUFACTURING AND DISTRIBUTION
 LIVESTOCK FARMING



SPECIFICATIONS

Voltage	120 - 277 VAC
Wattage	60W / 80W / 160W
Color Temp	4000 / 5000 Kelvin
Housing	Die cast aluminum alloy
Finish	Heat dissipating powder coat
Color	Gray
Lens	Shatterproof polycarbonate (not recommended for alkaline industrial cleaners)
Lifetime	>70,000 hrs L70
Efficacy	Up to 130 lm/W
CRI	≥ 80

Beam Angle	120°
Ambient Temperature	-20°C (-4°F) to 50°C (122°F)
Surge Protection	2.5 kV
Power Washing	Up to 1600 PSI
Protection	IP66 / IP69K
Warranty	5 Year Limited Warranty

LUMENS

60W	80W	160W
7,500	10,000	20,000

PRODUCT ORDERING SELECTION

LQPO				U		
Series	Length	Watts	Kelvin	Voltage	Mounting Options	Other Options
<input checked="" type="checkbox"/> LQPO	<input type="checkbox"/> 4 - 4'	<input type="checkbox"/> 060 - 60W <input type="checkbox"/> 080 - 80W	<input type="checkbox"/> 40 - 4000K <input type="checkbox"/> 50 - 5000K	<input checked="" type="checkbox"/> U - 120-277 VAC	<input type="checkbox"/> SBAC - Surface Bracket and 120" Adjustable Cable (2 Each Included Standard) <input type="checkbox"/> WM - Wall Mount Bracket	<input type="checkbox"/> P3 - 3 Pin Mini Connector Male Plug <input type="checkbox"/> 5P - 120 V Plug <input type="checkbox"/> L7P - Locking 277 V Plug
	<input type="checkbox"/> 8 - 8'	<input type="checkbox"/> 080 - 80W <input type="checkbox"/> 160 - 160W				

LQPO Series

The SABER™

MOUNTING OPTIONS

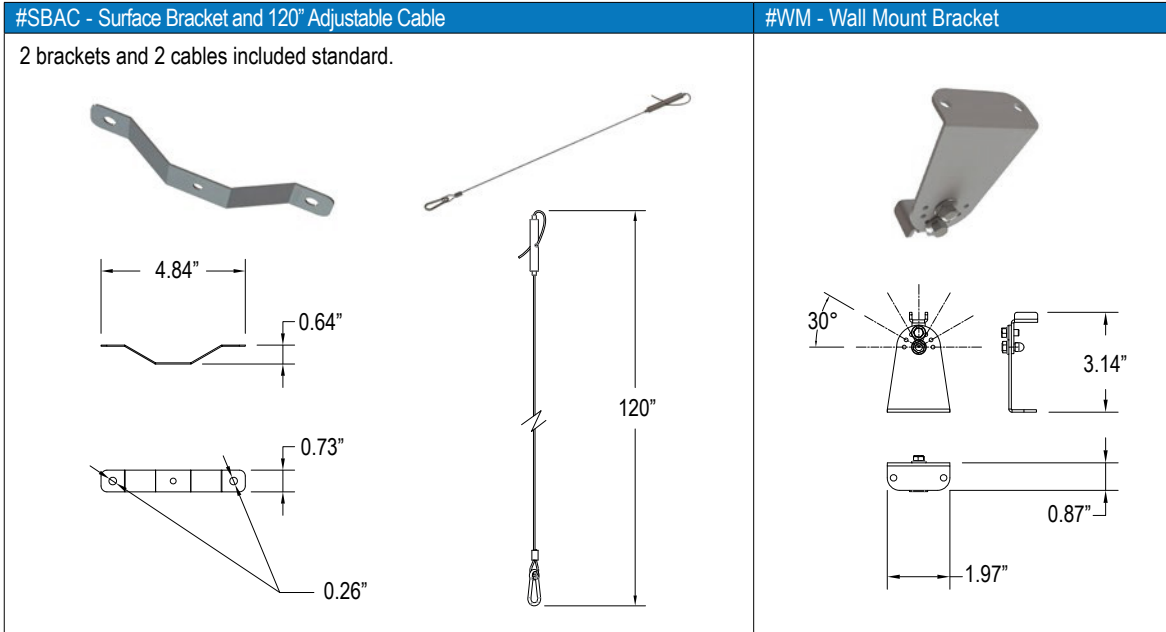

WEIGHTS AND DIMENSIONS

WEIGHTS

Length	lb.
LQPO-4 (4 foot)	8 lb.
LQPO-8 (8 foot)	12 lb.

