

EM-90 Series

Emergency Driver

LED Emergency Battery Backup

Cat. #	Type
Notes	

CERTIFICATIONS / RATINGS



KEY FEATURES AND BENEFITS

- Provides 40W output during emergency for at least 90 minutes.
- Simplified, labeled wiring system connects directly to driver for easy field installation.
- Self-adapt output voltage for operation of most indoor bay / flood light fixtures.
- Long life high temperature recyclable Li-ion battery.
- Constant power output in emergency mode.
- One piece design with metal housing.
- 2-in-1, waterproof test switch and indicator light.
- Self-diagnostic circuitry performs a 30-second discharge test monthly and a full 90-minute discharge test annually.
- Meets UL924 requirements.

SPECIFICATIONS

Voltage	100-347 VAC, 50/60Hz
Input Current	200mA max.
Input Power	12W max.
Recharge Time	24 hours
Discharge Time	90 minutes
Emergency Power	40W
Output Voltage	170VDC
Ambient Temperature	0°C (32°F) to 50°C(122°F)
Housing	Metal with corrosion resistant nylon powder-coat
Color	Red
Surge Protection	Meets ANSI/IEEE c62.41.2-2002
Battery	Lithium Ion
Power Factor	≥ 0.85
Protection	IP65
Warranty	5 Year Limited Warranty



Remote Control
(Order Separately)

Provides 40 watts of power for at least 90 minutes to your new or existing light fixtures.

PRODUCT ORDERING SELECTION

Order Number	Description
EMUFO-40170-TT	Emergency Driver, 40W, 90 Minutes, 100-347 VAC
EMUFO-Remote	Remote Control (1 Required Per Order)

EM-90 Series

Emergency Driver

Information

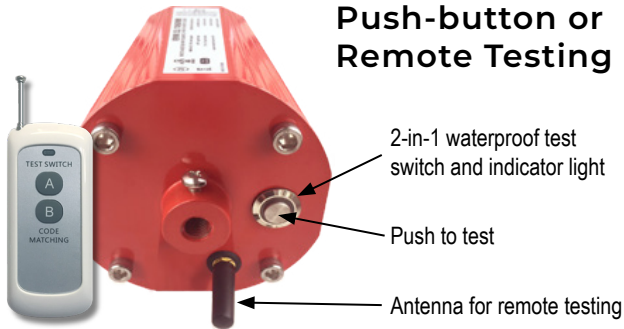

Easy To Identify Wiring



Each battery backup driver features color-coded and labeled wiring for ease of installation saving time and ensuring a properly wired fixture.

Emergency Operation Mode Formula

Step 1: Fixture Watts / Emergency Power Watts = X

Step 2: Fixture Lumens / X = Emergency Output Lumens

Example for a 200W / 20,000 lm fixture using EM-90 40W emergency driver.

Step 1: $200 / 40 = 5$ Step 2: $20,000 / 5 = 4,000 \text{ Lumens}$

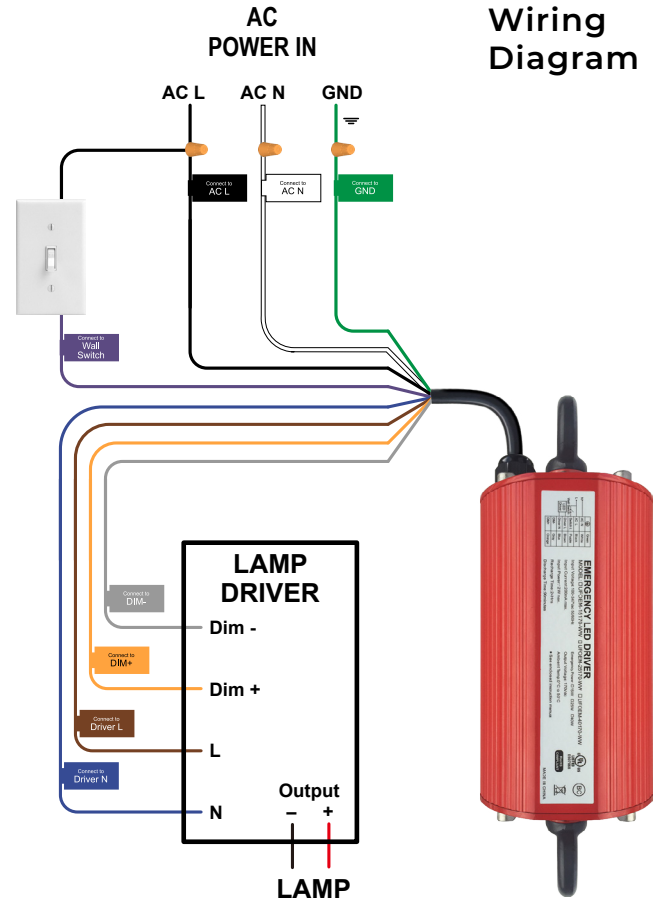

WEIGHTS AND DIMENSIONS

WEIGHT

7 lbs

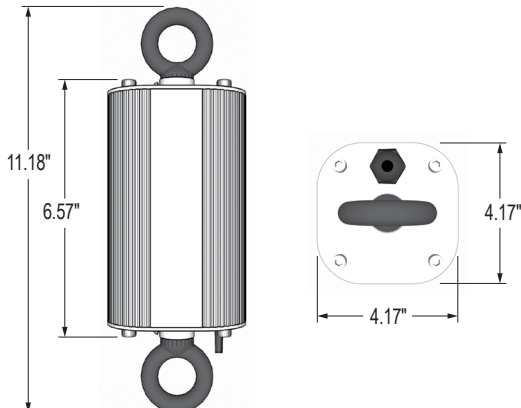

INCLUDED STANDARD

The following equipment is included standard with each EM-90

- Emergency LED Driver (qty 1)
- Screw-in Test Antenna (qty 1)
- 14" Safety Cable with Carabiner (qty 1)
- Heavy Duty Loop Hookups (qty 2)
- Heavy Duty Chain Link Connector (qty 1)